

Reading[®]



Pickup Caps

TRG
The Reading Group



Pickup Caps

DEPENDABLE | DURABLE | VERSATILE | RUGGED



- PATENTED hidden hinges
- EXCLUSIVE standard features and option packages
- LEGENDARY quality and durability
- TIMELESS design, maximized for efficiency



Standard Features: Space Cap / Ready Cap

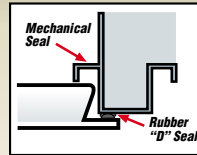

Dual Pro® Seal System

Compartments feature Reading's Dual Pro seal system, providing two levels of protection against the elements



Thicker Double Paneled Compartment Doors

Compartment doors are internally reinforced and feature a 1 1/4" thick door



Bolt-On Stainless Steel Hinges

Electro-zinc pins are fully concealed and never need oiling

Benefit: The most complete weather protection for compartments available. Doors operate smoothly in all weather conditions



Rivet-On Locks

- Complete stainless steel rotary, and stainless steel pan and chrome plated "T" handle style. Rotary locks used on Space Cap side doors and Ready Cap double rear door module. T-handle locks used on Ready Cap side doors, rear single door module and Space Cap rear drop-down gates
- Adjustable A-60 galvanized steel striker pins permit ease of adjustment on rotary locks
- Lock cylinders are guaranteed for life to the original owner

Benefit: Keeps compartment doors securely locked. Stainless steel is highly resistant to rust and has an attractive appearance. Rivet-on mounting permits ease of replacement (if necessary)



Rear Compartment Doors

- Full width lift-up doors are standard on Space Cap. The easy open, automatic rear lift-up door flips up on pneumatic props when the door latch is disengaged, and closes completely when partially lowered
- Full width single or double vertical rear doors are standard on Ready Cap (all rear door modules are single doors unless followed by a "-2" suffix)

Benefit: Provides easy access to the pickup bed from the rear of the truck

You take your work seriously. That's why we build our pickup caps for serious work. Reading caps are made of steel or aluminum and are built to last. Reading caps will help you organize and protect your tools and materials so you can get the job done faster and more efficiently. Premium materials, superb construction, and a five year limited warranty make a Reading cap the cap to top off your pickup.



A40-A60 Coating Weight Steel Construction

Reading caps feature two-sided, zinc coated A40-A60 coating weight steel construction

Acrylic E-Coat Priming

The caps enter a 12-stage process which thoroughly cleans, rinses, and primes the steel

- Caps are processed through a series of tanks filled with chemical agents that clean the steel
- Next, they are thoroughly rinsed free of contaminants
- Finally, caps are immersed in a tank of electrified primer. High voltage currents literally fuse the paint to every square inch of the steel, even the most hidden or recessed areas
- The primer is cured by baking the caps in high temperature ovens

Optional Powder Coat Finish

Only Reading offers this highly durable finish:

- Powder Coat is a fine polyester powder that is electrically bonded to the caps, inside and out. High temperatures melt the powder to form a smooth and durable white finish that exhibits high degrees of resistance to salt spray, corrosion, humidity, and scratching

Benefit: By combining A-60 galvanized steel and acrylic E-coat priming, Reading provides the best and most comprehensive protection against rust and corrosion available in the industry. Adding a powder coat finish further enhances this built-in protection



Fully Protected... Combining A40-A60 coating weight steel and acrylic E-coat priming provide layers of protection on both sides of the steel's surface



Space Caps



Space Caps



Standard Space Cap

SEC +8 Space Cap

SSE Space Cap

Space Cap Models:

- Standard models have two exterior compartments (compacts) or four exterior compartments (standard), plus an easy opening rear lift-up door
- SSE models have two exterior compartments plus lift-up doors on both sides for convenient access to the pickup bed
- SEC models have three compartments plus a lift-up door on curbside for access into the pickup bed
- Plus 8 models provide an additional 8 inches of inside headroom

Optional Items:

- 12" x 24" sliding front window
- 11 1/2" x 17 7/8" side windows, crank operated, vented and screened, or permanent 8" x 20" side window (available on plus 8 model only)
- Vertical rear door module
- Roof-mounted ladder rack
- Latch-Matic remote security system which locks or unlocks all compartments from up to 25' away

Space Cap Specifications									
Model	Pickup Bed (Wide Style)	Approx. Weight	A (Length)	B (Width)	C	D	E	F	G compartment clear door openings
SC-75FR	Ford Ranger (short)	328lbs.	751/8"	601/4"	361/4"	481/2"	61/4"	25"	107/8" x 681/8"
SC-75GS10	GM S-10 (short) & '04 Colorado/Canyon 6' bed	328lbs.	751/8"	601/4"	361/4"	481/2"	61/4"	25"	107/8" x 681/8"
SC-78T	Toyota Tundra (short)	346lbs.	773/4"	671/2"	431/2"	553/4"	61/4"	25"	107/8" x 681/8"
SC-78.5D	Dodge 61/2 ft. ('03 & later)	395lbs.	781/2"	681/2"	441/2"	563/4"	61/4"	25"	107/8" x 681/8"
SC-78.5D+8		435lbs.	781/2"	681/2"	441/2"	563/4"	141/4"	33"	107/8" x 681/8"
SC-80FLD	Ford 61/2 ft. std. (regular cab)	380lbs.	801/4"	681/2"	441/2"	563/4"	61/4"	25"	107/8" x 681/8"
SC-80FLD+8	Light duty-(under 8500 GVW) Heritage	422lbs.	801/4"	681/2"	441/2"	563/4"	141/4"	33"	107/8" x 681/8"
SC-81FLD	Ford 61/2 ft. '04 new F-150	380lbs.	813/8"	681/2"	441/2"	563/4"	61/4"	25"	107/8" x 681/8"
SC-81FLD+8		422lbs.	813/8"	681/2"	441/2"	563/4"	141/4"	33"	107/8" x 681/8"
SC-81GS	GM 61/2 ft. std. (Silverado & Sierra)	380lbs.	811/4"	671/2"	431/2"	553/4"	61/4"	25"	107/8" x 681/8"
SC-81GS+8		422lbs.	811/4"	671/2"	431/2"	553/4"	141/4"	33"	107/8" x 681/8"
SC-82DK	Dodge Dakota (short)	356lbs.	815/8"	631/4"	391/4"	511/2"	61/4"	25"	107/8" x 681/8"
SC-84FSD	Ford 63/4 ft. std. (super duty, '99 to current)	405lbs.	833/4"	70"	46"	581/4"	61/4"	25"	107/8" x 681/8"
SC-84FSD+8		450lbs.	833/4"	70"	46"	581/4"	141/4"	33"	107/8" x 681/8"
SC-86FR	Ford Ranger (long)	382lbs.	867/8"	601/4"	361/4"	481/2"	61/4"	25"	107/8" x 681/8"
SC-91GS10	GM S-10 (long)	410lbs.	911/4"	601/4"	361/4"	481/2"	61/4"	25"	107/8" x 381/4"
SC-99FLD	Ford 8 ft. std. (regular cab) light duty (under 8500lbs.GVW) Heritage	478lbs.	993/8"	681/2"	441/2"	563/4"	61/4"	25"	107/8" x 431/2"
SC-99FLD+8		529lbs.	993/8"	681/2"	441/2"	563/4"	141/4"	33"	107/8" x 431/2"
SC-99T	Toyota Tundra (long)	420lbs.	993/8"	671/2"	431/2"	553/4"	61/4"	25"	107/8" x 431/2"
SC-100FSD	Ford 8 ft. std. (super duty, '99 to current)	478lbs.	100"	70"	46"	581/4"	61/4"	25"	107/8" x 431/2"
SC-100FSD+8		500lbs.	100"	70"	46"	581/4"	141/4"	33"	107/8" x 431/2"
SC-100FLD	Ford 8 ft. '04 new F-150	478lbs.	1001/8"	681/2"	441/2"	563/4"	61/4"	25"	107/8" x 431/2"
SC-100FLD+8		500lbs.	1001/8"	681/2"	441/2"	563/4"	141/4"	33"	107/8" x 431/2"
SC-100GS	GM 8 ft. std. (Silverado & Sierra)	478lbs.	1003/8"	671/2"	431/2"	553/4"	61/4"	25"	107/8" x 431/2"
SC-100GS+8		500lbs.	1003/8"	671/2"	431/2"	553/4"	141/4"	33"	107/8" x 431/2"
SC-100.5D	Dodge 8 ft ('03 & later)	455lbs.	1001/2"	681/2"	441/2"	563/4"	61/4"	25"	107/8" x 431/2"
SC-100.5D+8		520lbs.	1001/2"	681/2"	441/2"	563/4"	141/4"	33"	107/8" x 431/2"

*One door models

Notes:

Due to many pickup bed dimension changes, Reading recommends that actual measurements of the pickup bed be taken to verify the model required prior to placing an order for any Space Cap or Ready Cap

Please check rear cab window protrusions, especially on compact size chassis with sliding windows. These may interfere with the front of the caps and not allow the cap to be positioned far enough forward for proper installation

If Reading's caps are ordered with optional front sliding windows, please add 3/4" for window and framing protrusion when checking length requirements

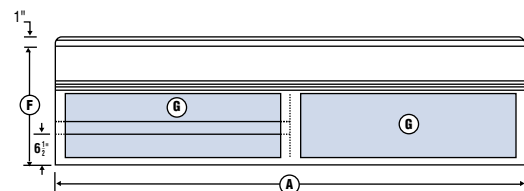

2-door models (side)

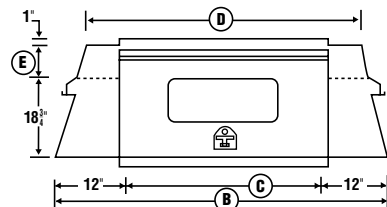

Rear view (vertical door is optional)

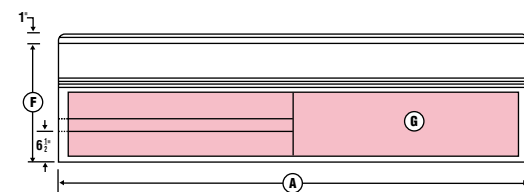

*1-door models (side)

Space Cap – Models SEC & SSE Specifications									
Model	Pickup Bed (Wide Style)	Approx. Weight	A (Length)	B (Width)	C	D (compartment clear door openings)	E	F	
SC-75FR SEC & SSE	Ford Ranger (short)	317lbs.	751/8"	601/4"	361/4"	481/2"	107/8" x 281/2"	161/4" x 363/4"	
SC-75GS10 SEC & SSE	GM S-10 (short) & '04 Colorado/Canyon 6' bed	317lbs.	751/4"	601/4"	361/4"	481/2"	107/8" x 281/2"	161/4" x 363/4"	
SC-78T SEC & SSE	Toyota Tundra (short)	326lbs.	773/4"	671/2"	431/2"	553/4"	107/8" x 281/2"	161/4" x 363/4"	
SC-78.5D SEC & SSE	Dodge 61/2 ft.(2003 & later)	380lbs.	781/2"	681/2"	441/2"	563/4"	107/8" x 331/2"	161/4" x 363/4"	
SC-80FLD SEC & SSE	Ford 61/2 ft. std. (regular cab) light duty (under 8500 GVW)-Heritage	368lbs.	801/4"	681/2"	441/2"	563/4"	107/8" x 331/2"	161/4" x 331/2"	
SC-81FLD SEC & SSE	Ford 61/2 ft. 2004 new F150	368lbs.	813/8"	681/2"	441/2"	563/4"	107/8" x 331/2"	161/4" x 331/2"	
SC-81GS SEC & SSE	GM 61/2 ft. std. (Silverado & Sierra)	368lbs.	811/4"	671/2"	431/2"	553/4"	107/8" x 331/2"	161/4" x 331/2"	
SC-82DK SEC & SSE	Dodge Dakota (short)	343lbs.	815/8"	631/4"	391/4"	511/2"	107/8" x 331/2"	161/4" x 331/2"	
SC-84FSD SEC & SSE	Ford 63/4 ft. std. (super duty '99 to current)	390lbs.	833/4"	70"	46"	581/4"	107/8" x 331/2"	161/4" x 331/2"	
SC-86FR SEC & SSE	Ford Ranger, (long)	370lbs.	867/8"	601/4"	361/4"	481/2"	107/8" x 381/4"	161/4" x 381/4"	
SC-91GS10 SEC & SSE	GM S-10 (long)	395lbs.	911/4"	601/4"	361/4"	481/2"	107/8" x 381/4"	161/4" x 381/4"	
SC-99FLD SEC & SSE	Ford 8ft. std. (regular cab) light duty (under 8500 GVW)-Heritage	462lbs.	993/8"	681/2"	441/2"	563/4"	107/8" x 431/2"	161/4" x 431/2"	
SC-99T SEC & SSE	Toyota Tundra (long)	409lbs.	993/8"	671/2" 671/2"	431/2"	553/4"	107/8" x 431/2"	161/4" x 431/2"	
SC-100FSD SEC & SSE	Ford 8 ft. std. (super duty '99 to current)	475lbs.	100"	70"	46"	581/4"	107/8" x 431/2"	161/4" x 431/2"	
SC-100FLD SEC & SSE	Ford 8ft. 2004 new F150	475lbs.	1001/8"	681/2"	441/2"	563/4"	107/8" x 431/2"	161/4" x 431/2"	
SC-100GS SEC & SSE	GM 8 ft. std. (Silverado & Sierra)	475lbs.	1003/8"	671/2"	431/2"	553/4"	107/8" x 431/2"	161/4" x 431/2"	
SC-100.5D SEC & SSE	Dodge 8 ft.('03 & later)	430lbs.	1001/2"	681/2"	441/2"	563/4"	107/8" x 431/2"	161/4" x 431/2"	

Notes:

Due to many pickup bed dimension changes, Reading recommends that actual measurements of the pickup bed be taken to verify the model required prior to placing an order for any Space Cap or Ready Cap

Please check rear cab window protrusions, especially on compact size chassis with sliding windows. These may interfere with the front of the caps and not allow the cap to be positioned far enough forward for proper installation

If Reading's caps are ordered with optional front sliding windows, please add 3/4" for window and framing protrusion when checking length requirements

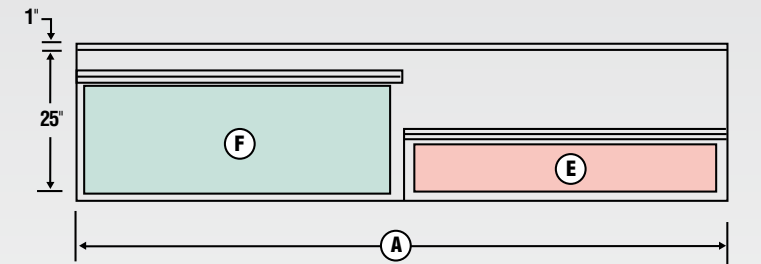

Road side SSE models

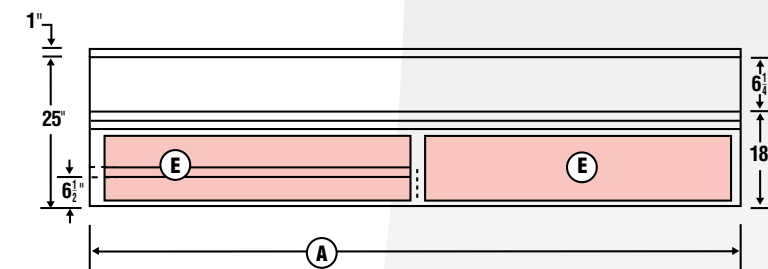

Road side SEC models

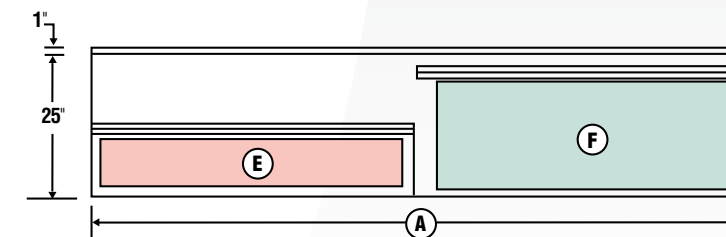

Curb side all SEC & SSE models

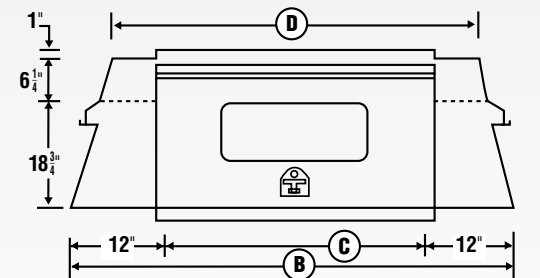

Rear view (vertical door is optional)

NOTE: One shelf is provided. Brackets on both sides of cap allow choice of mounting location



Ready Cap Specifications

Model	Pickup Bed (Wide Style)	Approx. Weight	A	B	C	D	E	F
RC-75FR5340	Ford Ranger (short)	289lbs.	751/8"	401/8"	533/4"	481/2"	361/4"	601/4"
RC-75GS105541	GM S-10 (short)	289lbs.	751/4"	41"	533/4"	481/2"	361/4"	613/4"
RC-75GS105643	Colorado & Canyon '04 6 ft.	290lbs.	751/4"	43"	551/2"	481/2"	361/4"	613/4"
RC-78T6141-2	Toyota Tundra (short)	304lbs.	773/4"	41"	61"	553/4"	431/2"	673/4"
RC-78.5D6444D-2	Dodge 61/2 ft. ('03 & later).	348lbs.	781/2"	44"	643/8"	563/4"	441/2"	73"
RC-80FLD6444-2	Ford 61/2 ft. std. (regular cab) light duty- (under 8500lbs. GVW) Heritage	336lbs.	801/4"	44"	64"	563/4"	441/2"	711/4"
RC-81FLD6446-2	Ford 61/2 ft. '04 new F150	341lbs.	813/8"	463/8"	64"	563/4"	441/2"	681/2"
RC-81GS6343-2	GM 61/2 ft. std. (Silverado & Sierra)	336lbs.	811/4"	431/4"	621/4"	553/4"	431/2"	693/4"
RC-82DK5741-2	Dodge Dakota (short)	315lbs.	815/8"	415/8"	571/4"	511/2"	391/4"	631/8"
RC-84FSD6544-2	Ford 63/4 ft. std. (super duty '99 to current)	359lbs.	833/4"	44"	643/8"	581/4"	46"	741/2"
RC-86FR5340	Ford Ranger, (long)	336lbs.	867/8"	401/8"	533/4"	481/2"	361/4"	601/4"
RC-91GS105541	GM S-10 (long)	360lbs.	911/4"	41"	543/4"	481/2"	361/4"	613/4"
RC-99FLD6444-2	Ford 8ft. std. (regular cab) light duty- (under 8500lbs. GVW) Heritage	422lbs.	993/8"	44"	64"	563/4"	441/2"	711/4"
RC-99T6141-2	Toyota Tundra (long)	403lbs.	993/8"	41"	61"	553/4"	431/2"	673/4"
RC-100FSD6544-2	Ford 8 ft. std. (super duty '99 to current)	433lbs.	100"	44"	643/8"	581/4"	46"	741/2"
RC-100FLD6446-2	Ford 8ft. '04 new F150	438lbs.	1001/8"	463/8"	64"	563/4"	441/2"	681/2"
RC-100GS6343-2	GM 8ft. std. (Silverado & Sierra)	433lbs.	1003/8"	431/4"	621/4"	553/4"	431/2"	693/4"
RC-100.5D6444D-2	Dodge 8 ft. ('03 & later)	453lbs.	1001/2"	44"	643/8"	563/4"	441/2"	73"

All rear door modules are single doors, unless followed by a "-2" suffix.

Notes:

Due to many pickup bed dimension changes, Reading recommends that actual measurements of the pickup bed be taken to verify the model required prior to placing an order for any Reading cap.

Please check rear cab window protrusions, especially on compact size chassis with sliding windows. These may interfere with the front of the caps and not allow the cap to be positioned far enough forward for proper installation.

If Reading's caps are ordered with optional front sliding windows, please add 3/4" for window and framing protrusion when checking length requirements.

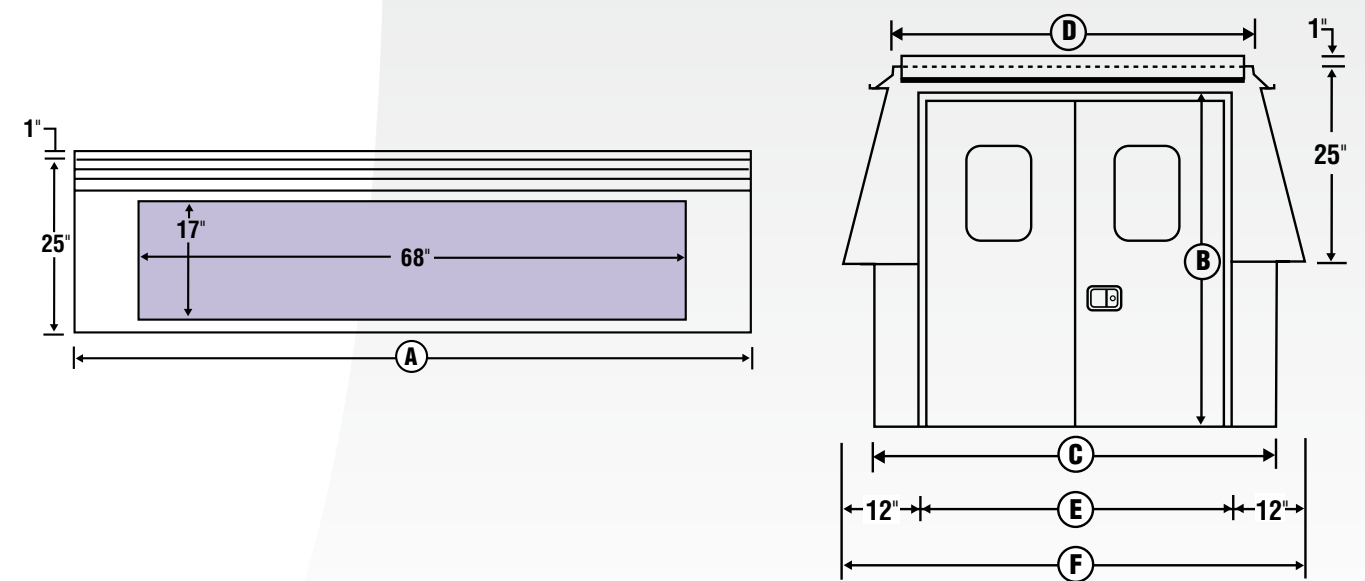

Ready Cap Models

Full-width, full-height side and rear doors let you reach everything inside the pickup bed quickly and easily. The side doors operate on pneumatic props that flip up automatically when the T-handle door latch is disengaged.

Optional Items:

- Solid side panels
- Lift-up rear door
- Latch-Matic remote security system which locks or unlocks all compartments from up to 25' away.
- 11" x 14" or 8" x 58 1/2" windows in lift-up side doors
- Heavy-gauge steel shelf racks to help you organize your truck
- Roof-mounted ladder rack

The Reading Group has a full line of trucks built for the long haul.



Cut-Away Van Bodies



Steel Contractor Bodies



Steel Stake and Platform Bodies



Steel Landscaper



Utility Bodies



Dump Bodies



Dry Freight Van Bodies



Redi-Dek™



Forestry Bodies



Steel Service Bodies



Drop Side Dump Bodies



Aluminum Service Bodies



Composite Landscaper



S.M.A.R.T. Racks



Composite Contractor Bodies



Service Vans
57" and 75" single and dual wheel



Locations
Abington, PA
Atlanta, GA
Bowmansville, PA

Cleveland, OH
Clinton, MD
Columbus, OH
Denver, PA

LaGrange, TX
Louisville, KY
Pontiac, MI
Portland, OR

Reading, PA
Seneca, PA
Suffolk, VA
Tampa, FL

SOLD AND SERVICED LOCALLY BY

All dimensions subject to plus or minus tolerance of 1/4" and all dimensions and specifications are subject to change without notice. Some items displayed in photographs are optional. Alum-Fill, Alum-Chock, Dual-Pro, Extend-A-Shelf, Grip-'n-Glide, Latch-Matic, Marauder, Reading, Redi-Dek, Rhino Linings, Rugged American, S.M.A.R.T. Racks, Spacemaker, Tool-Mates, and TUFF STUFF are registered trademarks of The Reading Group, LLC in the United States and some foreign countries. The Reading kangaroo is a trademarked image and may not be reproduced or used without express permission from The Reading Group.

TheReadingGroup.us

TRG10-PUC-15M-07

© 2010 The Reading Group, LLC