

MECHANICS BODY PAL Pro 20

Mechanics Bodies, Service Cranes & Compressors
Built for the Modern Work Truck.

LIFETIME EXCELLENCE





With the best equipment for the job, add a competitive edge to your business in a range of industries. Our mechanics trucks are a reliable partner in: Construction, Roadway, Railway, Agriculture, Oil & Gas, Mining, Utilities and Municipalities.



APPLICABLE CRANE MODELS

- PSC 3216
- PSC 4016
- PSC 4025

APPLICABLE COMPRESSORS

- PRC 45V



HIGHLIGHTS

The PAL Pro 20 is our newest light-weight mechanics body in 9' and 11' standard configurations built to accommodate service cranes up to 20,000 ft*lbs. of lifting capacity. Designed with two-piece doors bonded with automotive adhesive instead of welding, full length channel drip rails, reinforced raised compartments and compartment tops, 316 marine grade stainless steel hinges, and 3 point latching on all doors for added security. All these features, and more, come standard on the PAL Pro 20 package.

Rely on the right equipment for the job with a factory designed, built and tested mechanics body.

NON-MARRING BOOM REST

Adjustable non-marring boom support E-coated black.

DOOR DESIGN ELIMINATE WELDING

Double panel doors with internal C-channel stiffeners, adhered with structural adhesive.



HINGES SECURITY & RUST PREVENTION

316 marine grade stainless steel hinges with concealed leaves and full length rods for combating rust and improving theft prevention.

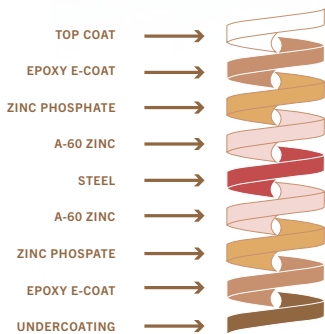

E-COAT CORROSION PROTECTION

PALFINGER's 12 step electrophoretic deposition dip process cleans the body and applies primer to the metal surfaces, ensuring complete coverage and automotive grade corrosion protection.

SIDEPACK REINFORCED MOUNT UP

All compartment tops are reinforced to prevent fatigue and cracking when heavy items like welders, tool boxes, and compressors are mounted to the top of your body.

INTERNAL GUSSETS PREVENTS BODY CRACKING

Every raised compartment comes with PALFINGER's engineered gussets for increased protection against the body cracking in the door corner.

FEATURES

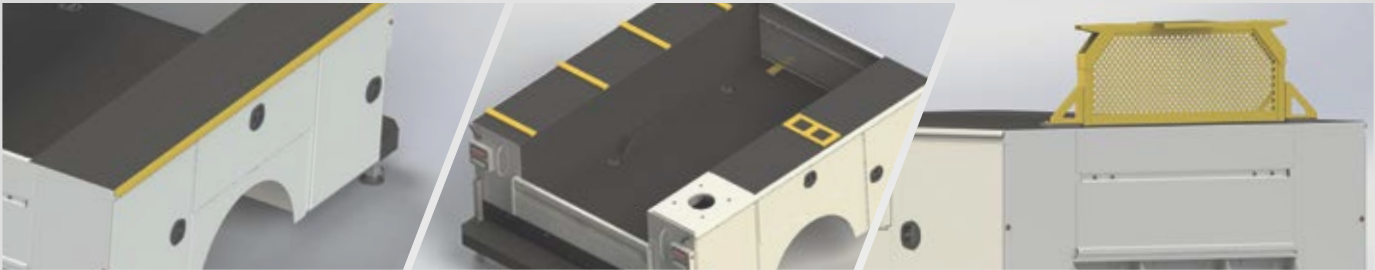

DRIP RAIL STAY DRY

Full length channel drip rails divert water away from the compartment openings.

THREADED WELDMENT OPTIONS TO PROTECT YOUR BODY

Boom rest, welder, compressor, EnPak, Air-n-Arc and AirPak mounts are available from the factory to eliminate the need to drill holes in the body.

HEADACHE RACK SAVES COSTLY REPAIRS

This light bar bracket with a punched screen prevents cargo area contents from making contact with the rear window of the cab – saving you from costly rear window repairs and cleanup.



ALUMINUM DIVIDER TRAYS LIGHT WEIGHT SHELVEING

Aluminum divider trays designed to reduce weight and resist corrosion.

ALUMINUM ROLL OUT DRAWERS LIGHT WEIGHT STORAGE

Tool drawer units options available in aluminum with 4 longitudinal dividers and padded floors.

3 POINT COMPRESSION LATCHES IMPROVED SECURITY & SEALING

Latches are designed for added security and solid contact with the automotive bulb seal on the door frame

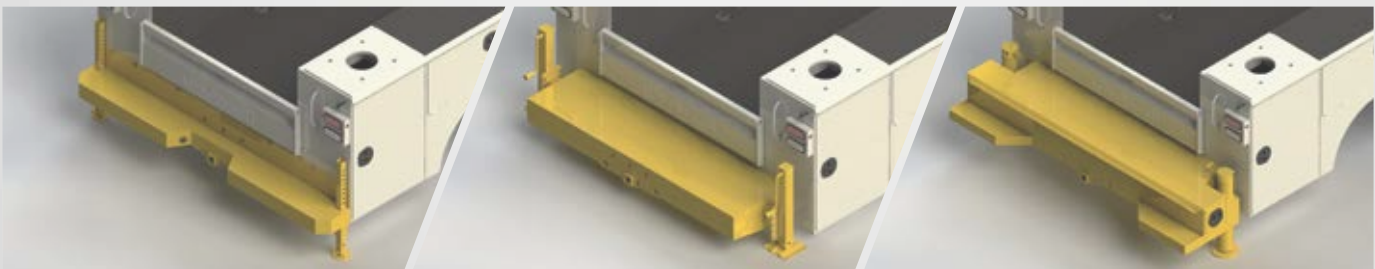

STEP BUMPERS LIGHT WEIGHT LOAD SPACE ACCESS

10" or 17" tread plate step bumper with recess for hitch receiver and crank down outriggers or drop down stabilizers.

20" WORK BENCH BUMPER HEAVY DUTY WORK SURFACE

20" deep work bench bumper with hitch receiver and bolt on manual or hydraulic outriggers.

WORK BENCH W/ THRU COMPARTMENT STORAGE & HEAVY DUTY WORK SURFACE

12" or 21" work bench bumper with hitch receiver and cross tube for extending manual or hydraulic outriggers.

STANDARD CONFIGURATIONS

20-9

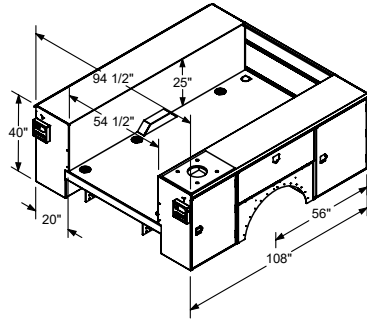

9' standard configuration
40" tall compartment heights
14" tall one handed tailgate
Reinforced compartment tops

20-9CS

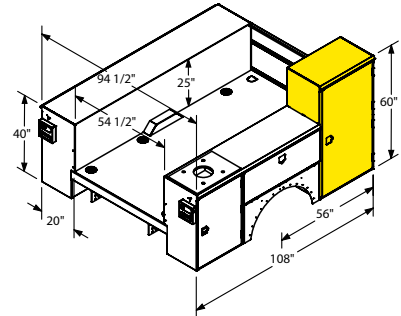

9' standard configuration
40" tall compartment heights
CS front compartment raised to 60"
14" tall one handed tailgate
Reinforced compartment tops
Reinforced raised compartment

20-9SSCS

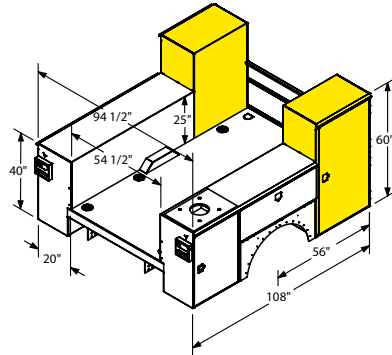

9' standard configuration
40" tall compartment heights
SS & CS front compartments raised to 60"
14" tall one handed tailgate
Reinforced compartment tops
Reinforced raised compartments

20-11

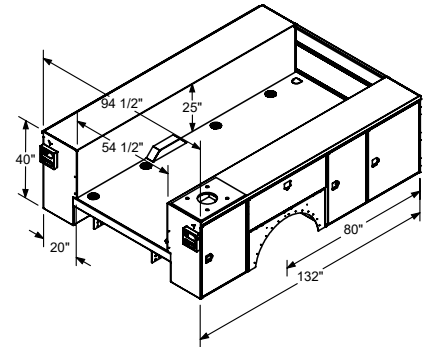

11' standard configuration
40" tall compartment heights
14" tall one handed tailgate
Reinforced compartment tops

20-11CS

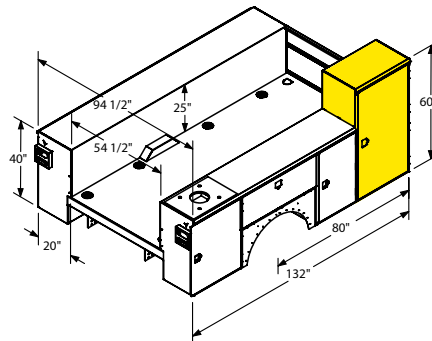

11' standard configuration
40" tall compartment heights
CS front compartment raised to 60"
14" tall one handed tailgate
Reinforced compartment tops
Reinforced raised compartment

20-11SSCS

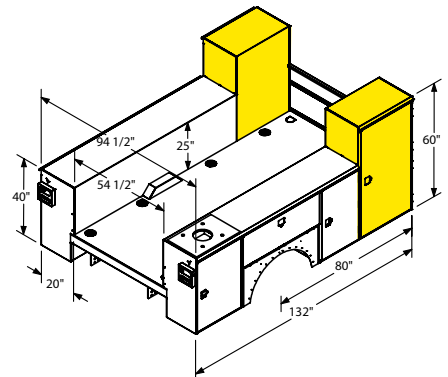

11' standard configuration
40" tall compartment heights
SS & CS front compartments raised to 60"
14" tall one handed tailgate
Reinforced compartment tops
Reinforced raised compartments

SERVICE CRANE

PRODUCT RANGE

TECHNICAL SPECIFICATIONS

MODEL	CAPACITY	RATED LIFTING MOMENT	MAX LIFTING MOMENT	BOOM EXTENSIONS	BOOM LENGTH	WINCH SPEED	STANDARD WEIGHT	CHASSIS SPECIFICATION
PSC 3216 E	4,000 lbs. (1,814 kg)	12,500 ft*lbs. (17 kNm (1.7 mt))	14,560 ft*lbs. (19.6 kNm (2 mt))	1 Hydraulic + 1 Manual (2 Hydraulic Option)	16 ft. (4.9 m)	21.2 ft./min (6.46 m/min)	650 lbs. (295 kg)	Class 3
PSC 3216 H	4,000 lbs. (1,814 kg)	12,500 ft*lbs. (17 kNm (1.7 mt))	14,560 ft*lbs. (19.6 kNm (2 mt))	1 Hydraulic + 1 Manual (2 Hydraulic Option)	16 ft. (4.9 m)	29.7 ft./min (9.05 m/min)	630 lbs. (286 kg)	Class 3
PSC 4016 E	4,000 lbs. (1,814 kg)	18,500 ft*lbs. (25.1 kNm (2.6 mt))	23,235 ft*lbs. (31.4 kNm (3.2 mt))	1 Hydraulic + 1 Manual (2 Hydraulic Option)	16 ft. (4.9 m)	21.2 ft./min (6.46 m/min)	650 lbs. (295 kg)	Class 3
PSC 4016 H	4,000 lbs. (1,814 kg)	18,500 ft*lbs. (25.1 kNm (2.6 mt))	23,235 ft*lbs. (31.4 kNm (3.2 mt))	1 Hydraulic + 1 Manual (2 Hydraulic Option)	16 ft. (4.9 m)	29.7 ft./min (9.05 m/min)	630 lbs. (286 kg)	Class 3
PSC 4025 E	4,000 lbs. (1,814 kg)	18,500 ft*lbs. (25.1 kNm (2.6 mt))	20,585 ft*lbs. (27.9 kNm (2.9 mt))	2 Hydraulic	25 ft. (7.6 m)	21.2 ft./min (6.46 m/min)	1,010 lbs. (458 kg)	Class 3
PSC 4025 H	4,000 lbs. (1,814 kg)	18,500 ft*lbs. (25.1 kNm (2.6 mt))	20,585 ft*lbs. (27.9 kNm (2.9 mt))	2 Hydraulic	25 ft. (7.6 m)	29.7 ft./min (9.05 m/min)	995 lbs. (451 kg)	Class 3
PSC 5025 E	5,000 lbs. (2,268 kg)	32,500 ft*lbs. (44.2 kNm (4.5 mt))	36,360 ft*lbs. (49.3 kNm (5 mt))	2 Hydraulic	25 ft. (7.6 m)	18.8 ft./min (5.73 m/min)	1,170 lbs. (530 kg)	Class 4
PSC 5025 H	5,000 lbs. (2,268 kg)	32,500 ft*lbs. (44.2 kNm (4.5 mt))	36,360 ft*lbs. (49.3 kNm (5 mt))	2 Hydraulic	25 ft. (7.6 m)	56 ft./min (17.07 m/min)	1,155 lbs. (525 kg)	Class 4
PSC 6025 E	6,000 lbs. (2,750 kg)	38,500 ft*lbs. (52.2 kNm (5.3 mt))	42,800 ft*lbs. (58.0 kNm (5.9 mt))	2 Hydraulic	25 ft. (7.6 m)	43.3 ft./min (13.20 m/min)	1,280 lbs. (580 kg)	Class 4
PSC 6025 H	6,000 lbs. (2,750 kg)	38,500 ft*lbs. (52.2 kNm (5.3 mt))	42,800 ft*lbs. (58.0 kNm (5.9 mt))	2 Hydraulic	25 ft. (7.6 m)	51 ft./min (15.54 m/min)	1,230 lbs. (560 kg)	Class 4
PSC 8029 H	8,000 lbs. (3,650 kg)	43,000 ft*lbs. (58.3 kNm (5.9 mt))	49,180 ft*lbs. (66.5 kNm (6.8 mt))	2 Hydraulic	29 ft. (8.9 m)	60 ft./min (18.28 m/min)	2,149 lbs. (975 kg)	Class 5
PSC 10829 H	10,800 lbs. (4,900 kg)	62,000 ft*lbs. (84.1 kNm (8.6 mt))	68,900 ft*lbs. (93.2 kNm (9.5 mt))	2 Hydraulic	29 ft. (8.9 m)	60 ft./min (18.28 m/min)	2,407 lbs. (1,092 kg)	Class 6
PSC 12529 H	12,500 lbs. (5,700 kg)	72,000 ft*lbs. (97.6 kNm (10 mt))	79,450 ft*lbs. (107.7 kNm (11 mt))	2 Hydraulic	29 ft. (8.9 m)	60 ft./min (18.28 m/min)	2,731 lbs. (1,239 kg)	Class 6
PSC 14029 H	14,000 lbs. (6,400 kg)	86,000 ft*lbs. (116.6 kNm (11.9 mt))	94,676 ft*lbs. (128.4 kNm (13 mt))	2 Hydraulic	29 ft. (8.9 m)	60 ft./min (18.28 m/min)	2,833 lbs. (1,285 kg)	Class 7



OSP_PALPRO20_06/20

Cranes shown in the leaflet are partially optional equipped and do not always correspond to the standard version. All PSC models are subject to change as PALFINGER updates, improves, and technologically advances their cranes and the industry.

OMAHA STANDARD PALFINGER
 3501 S. 11th Street | Council Bluffs, IA
 51501-0876 | USA
 T + 1 800 279 2201
 info@palfingerna.com

PALFINGER.COM