

KNAPHEIDE
SINCE 1848



FORD
STEEL
SERVICE BODIES

KNAPHEIDE STEEL SERVICE BODIES



STANDARD STEEL SERVICE BODIES

With a rugged steel construction and external storage for your tools and equipment, the Service Body is a key component in your day-to-day productivity.

The external compartments offer protection from outside elements and allow technicians to access their equipment without having to climb into the truck bed.

Staying organized both on and between job sites is important. Get maximum efficiency with a Knapheide Service Body.

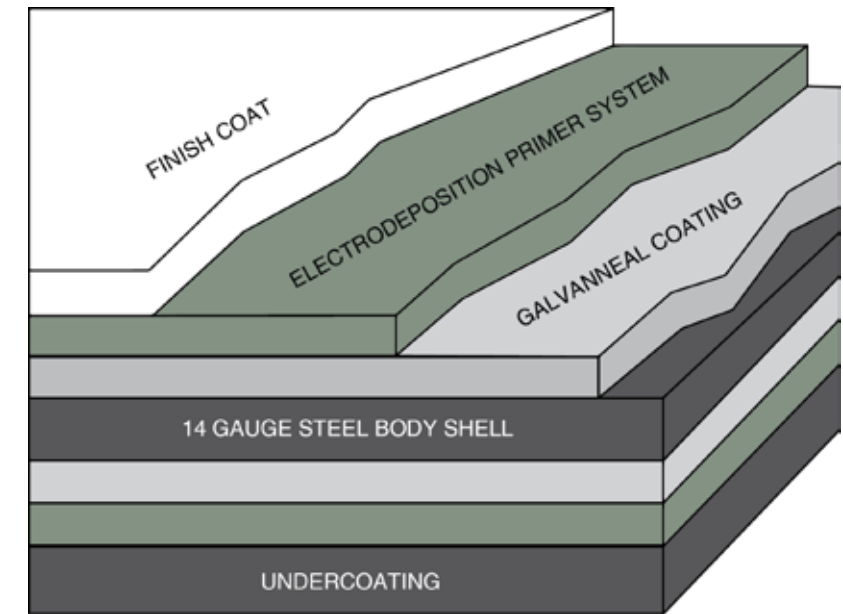

SERVICE BODY STEEL SHELL

Rugged two-sided A-40 galvanneal steel body shell with a six year warranty. Complete undercoating provides an additional layer of corrosion protection.

POPULAR VOCATIONS



CONSTRUCTION

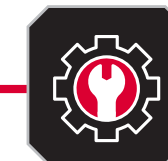

MUNICIPALITIES/
UTILITIES



OIL/MINING/GAS

A. DOUBLE-SHELL, 20-GAUGE, TWO-SIDED A-40 GALVANNEAL STEEL
compartment doors

B. ADJUSTABLE SECURITY RING STRIKERS
provide a weather-tight seal

C. INTERIOR COVER
protects internal latch from damage

D. SLAM-LOCK TAILGATE
with one-hand center release

E. UPGRADED SURFACE MOUNT LIGHTING SYSTEM
features LED S/T/T and B/U, LED strobe option* with (8) selectable patterns, and built-in reflectivity for additional safety**

*Additional wire harness required for strobe lights
**Lights covered by 3-year limited warranty



Note: Body may be shown with optional features.

FEATURES NOT SHOWN

EXCLUSIVE "RETURN FLANGE" FLOOR DESIGN
provides support

E-COAT PROTECTION
Knapheide Bodies are fully immersed in Knapheide's 12-step, electrodeposition prime paint system for superior corrosion resistance.

QUICK-MOUNT INSTALLATION
allows for fast, safe mounting

COMPARTMENT FEATURES



DOUBLE-SPRING OVER-CENTER RETAINER
on vertical compartment doors eliminate involuntary swing



NEOPRENE DOOR SEALS
protect compartments from the weather



CONTINUOUS STAINLESS STEEL HINGES
are pry-proof and corrosion-resistant



INTERIOR LIGHT GUARDS
protect recessed lighting and wiring

STANDARD SHELVING



STREET AND CURB SIDE FRONT VERTICAL COMPARTMENTS
Two adjustable divider shelves and dividers, with a 250-lb. capacity (1st and 2nd vertical 132" bodies only)



STREET AND CURB SIDE FULL HEIGHT REAR VERTICAL COMPARTMENTS
One adjustable divider shelf and dividers, with a 250-lb. capacity



CURB SIDE HORIZONTAL COMPARTMENT
One adjustable divider shelf and dividers, with a 250-lb. capacity

60" tall bodies include an extra divider shelf in each compartment, including one in the streetside horizontal

COMPARTMENT CONFIGURATIONS



500 SERIES COMPARTMENTS

The 500 Series Service Bodies feature a horizontal compartment that stretches from the first vertical compartment to the end of the body with a small, rear lower compartment.



600 SERIES COMPARTMENTS

The 600 Series Service Bodies feature a horizontal compartment that is positioned over the wheel well and one vertical compartment in the front of the body and one at the rear of the body.



700 SERIES COMPARTMENTS

The 700 Series has 500 Series configuration on the curb side and 600 Series on the street side.



LOW PROFILE BODY

Low Profile Bodies, denoted by "LP", offer greater visibility from the cab while only sacrificing 4" of the body height compared to a standard Service Body.



RAISED FRONT COMPARTMENTS

This configuration raises the curb side front vertical compartment to 60" tall, denoted by "60". "60-L" indicates raised front compartment on the street side (left) of the body, and "60-B" indicates raised front compartments on both sides.

FLIP TOP COMPARTMENTS

Flip Tops, denoted by "F", allow for greater internal storage, organization and flexibility. Knapheide Flip Tops have a slammable top lid door and a convenient one-hand release located in the horizontal compartment.

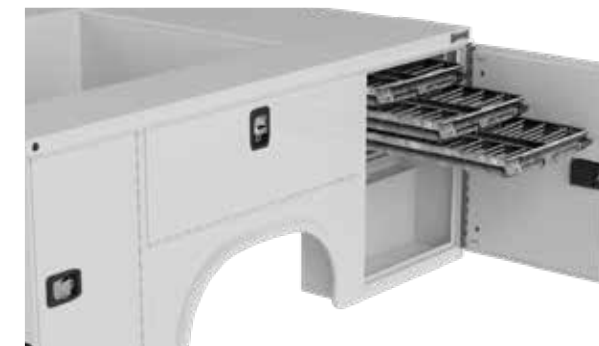

THREE-DRAWER UNIT



TWO-DRAWER UNIT

PLUS 50 TRANSVERSE COMPARTMENTS

Plus 50 models feature a transverse compartment in the curb side front vertical extending to the street side compartment back. Plus 50 models have 50% more effective storage capacity. Models are denoted by "50".

Depending on body model, compartments have either two or three drawers, 59" or 69" long. All drawers are rated for 250-lb. and have dividers every 4".

POPULAR OPTIONS

BUMPERS

Knapheide bumpers are constructed with work in mind. With three configurations, we have a bumper for every need. Select bumpers available with KnapLiner coating for additional friction and durability.



HITCH RECESS BUMPERS



STEP BUMPERS



STRAIGHT BUMPERS

CANOPY ROOF

The canopy roof option allows you to fully enclose your cargo area. Canopy roofs are available in three heights, straight sides, and with stationary or telescopic roofs. Full width roofs are also available. For a tapered-side one-piece body design, take a look at our KUVcc product line.



STRAIGHT SIDES



TELESCOPIC ROOF



SIDE ACCESS DOORS



SIDE LADDER RACKS



REAR ACCESS DOOR



TELESCOPIC SLIDING ROOF

Telescopic sliding roofs offer a robust enclosure for the cargo space of your Service Body, allowing you to protect your tools and equipment from theft and weather.

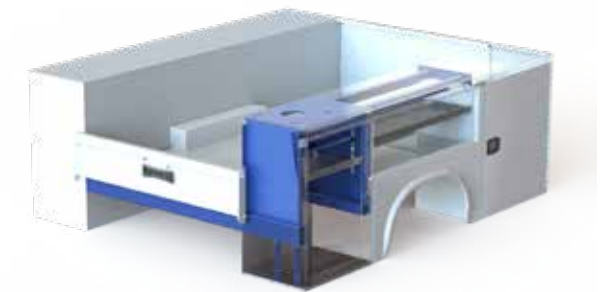

CRANE REINFORCEMENT KIT

The crane reinforcement kit option allows you to incorporate a crane up to 4,000 lb. capacity (16,000 ft-lb. max.) onto the rear curb side corner of your body.

RACKS

Adding a rack to your Service Body increases your storage space by getting your ladders and other long tools or equipment up and out of the way, making room to haul more items in your cargo area.

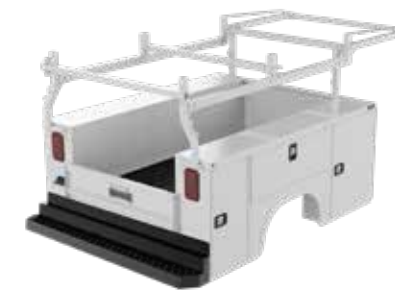

UTILITY RACK
1,000 lb. capacity - forklift loadable



SIDE MOUNT LADDER RACK
150 lb. capacity



OVERCAB MATERIAL RACK
Kargo Master



OVERHEAD LADDER RACK
300 lb. capacity

NOT PICTURED (APPLIES TO SIDE MOUNT & OVERHEAD LADDER RACKS):

LADDER RACK ROLLERS

LADDER RACK RAILS

POPULAR OPTIONS



MASTER LOCKS



POWER LOCKS



FRONT STROBE



LED COMPARTMENT LIGHTS



FLEX STEPS



CABLE STEPS



ALUMINUM DRAWERS



STEEL DRAWERS



ALUMINUM TREAD PLATE TRIM KITS



PULL-OUT SHELVES



BOTTLE GAS RETAINER



ROCK GUARDS



MOUNTING KITS FOR REMOVABLE CRANE (SPITZLIFT)



METER TRAY WITH HOLES



PULL-OUT TRAY



MODULAR CAB GUARD

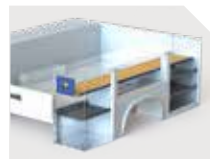

REAR ACCESS DOOR WITH FULL-LENGTH SHELF



E-TRACK & ACCESSORIES



SINGLE POINT OR THREE POINT T-HANDLE



REAR ACCESS DOOR



GRAB HANDLES



WHEEL CHOCK HOLDER - FENDER SKIRT



CARGO TIE-DOWNS



MODEL OPTIONS

40" CA SINGLE REAR WHEEL

MODEL	TYPE	HEIGHT	WEIGHT
680	Standard	40"	875 lb.
680LP	Low Profile	36"	827 lb.
680F	Flip Top (L)	37.25"	942 lb.
680F40	Flip Top (H)	41.25"	989 lb.

TRUCK	CAB	GVWR
X2A/X2B	Super	9,900/10,800 lb.
W2A/W2B	Crew	9,900/10,800 lb.
X3A/X3B	Super	10,000/11,800 lb.
W3A/W3B	Crew	10,000/12,400 lb.

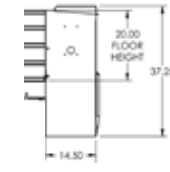
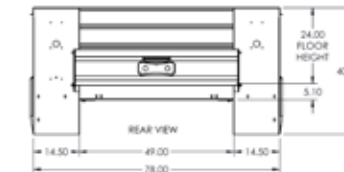
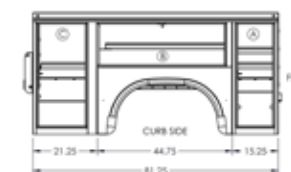

"F" models only

56" CA SINGLE REAR WHEEL

MODEL	TYPE	HEIGHT	WEIGHT
696	Standard	40"	1,048 lb.
696LP	Low Profile	36"	993 lb.
696F	Flip Top (L)	37.25"	1,125 lb.
696F40	Flip Top (H)	41.25"	1,181 lb.
696D38*	Standard	40"	1,064 lb.
696D38LP*	Low Profile	36"	1,005 lb.
696D38F*	Flip Top (L)	37.25"	1,142 lb.

TRUCK	CAB	GVWR
F2A/F2B	Regular, Gas	9,000/10,600 lb.
X2A/X2B	Super, Gas	9,000/10,800 lb.
W2A/W2B	Crew, Gas	9,000/10,800 lb.
F3A/F3B	Regular, Gas	9,900/11,400 lb.
X3A/X3B	Super, Gas	9,900/11,800 lb.
W3A/W3B	Crew, Gas	9,900/11,900 lb.
F2A/F2B/F3A/F3B	Regular, Diesel	9,900/11,500 lb.
X2A/X2B/X3A/X3B	Super, Diesel	9,900/11,500 lb.
W2A/W2B/W3A/W3B	Crew, Diesel	9,900/12,400 lb.

*D38 models denote 38" wide floor and 20" deep compartments.
Note: Chassis with GVWR 10,000 lb. and under subject to curb weight limits.
Not all engine/drive and body combinations are applicable.

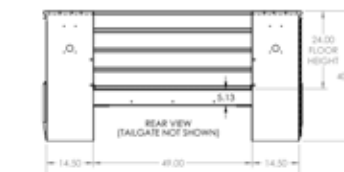
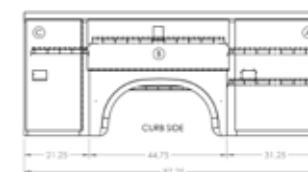

"F" models only

MODEL OPTIONS

56" CA DUAL REAR WHEEL

MODEL	TYPE	HEIGHT	WEIGHT	TRUCK	CAB	GVWR
696D54	Standard	40"	1,205 lb.	F3C/F3D	Regular	13,000/14,000 lb.
696D54LP	Low Profile	36"	1,146 lb.	X3C/X3D	Super	13,000/14,000 lb.
696D54F	Flip Top (L)	37.25"	1,279 lb.	W3C/W3D	Crew	13,000/14,000 lb.
696D54F40	Flip Top (H)	41.25"	1,339 lb.			

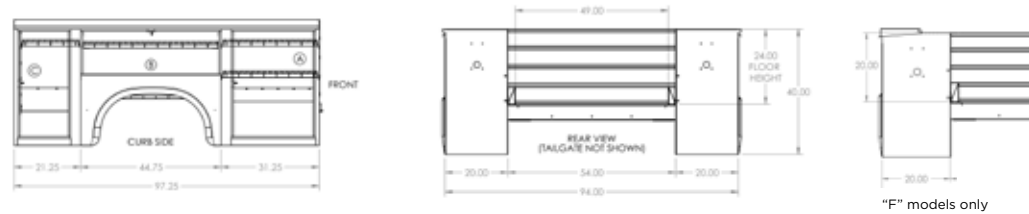

82" CA SINGLE REAR WHEEL - FORD TRANSIT

MODEL	TYPE	HEIGHT	WEIGHT	TRUCK	CAB	GVWR
6129-FT	Standard	43"	1,503 lb.	R5Z/R7Z	Regular	9,070 lb.
				W5Z/W7Z	Regular	9,500 lb.

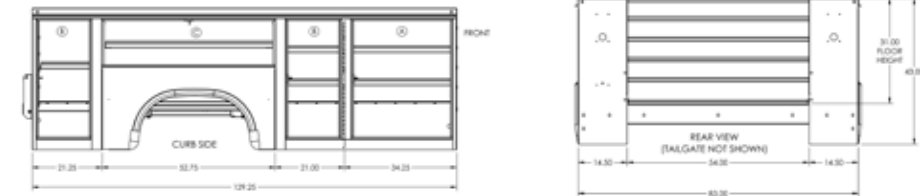

60" CA SINGLE REAR WHEEL

MODEL	TYPE	HEIGHT	WEIGHT	TRUCK	CAB	GVWR
6108	Standard	40"	1,147 lb.	F3E	Regular, Gas	9,800/10,900 lb.
6108LP	Low Profile	36"	1,094 lb.	F3F	Regular, Diesel	9,800/11,500 lb.
6108F	Flip Top (L)	37.25"	1,239 lb.	X3E	Super, Gas	9,800/11,300 lb.
6108F40	Flip Top (H)	41.25"	1,295 lb.	X3F	Super, Diesel	9,800/11,500 lb.
				W3E	Crew, Gas	9,800/11,400 lb.
				X3F	Crew, Diesel	9,800/11,500 lb.

Note: Chassis with GVWR 10,000 lb. and under subject to curb weight limits. Not all engine/drive and body combinations are applicable.

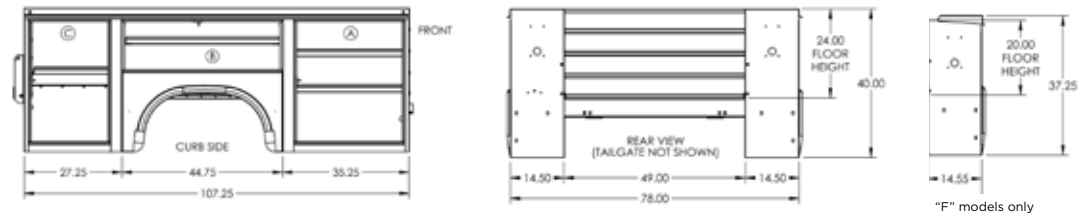

84" CA DUAL REAR WHEEL

MODEL	TYPE	HEIGHT	WEIGHT	TRUCK	CAB	GVWR
6132D54	Standard	40"	1,590 lb.	F3G/F3H	Regular	14,000 lb.
6132D54LP	Low Profile	36"	1,518 lb.	F4G/F4H	Regular	15,000/16,500 lb.
6132D54F	Flip Top (L)	37.25"	1,710 lb.	X4G/X4H	Super	15,000/16,500 lb.
6132D54F40	Flip Top (H)	41.25"	1,785 lb.	W4G/W4H	Crew	15,000/16,500 lb.
6132D54H46	Standard	46"	1,709 lb.	F5G/F5H	Regular	17,500/19,500 lb.
6132D54H60	Standard	60"	1,986 lb.	X5G/X5H	Super	17,500/19,500 lb.
				W5G/W5H	Crew	17,500/19,500 lb.
				F600	Regular	22,000 lb.
				F6K	Regular	22,000 lb.
				F6L	Regular	22,000 lb.

60" CA DUAL REAR WHEEL

MODEL	TYPE	HEIGHT	WEIGHT	TRUCK	CAB	GVWR
6108D54	Standard	40"	1,306 lb.	F3G/F3H	Regular	14,000 lb.
6108D54LP	Low Profile	36"	1,245 lb.	X3G/X3H	Super	14,000 lb.
6108D54F	Flip Top (L)	37.25"	1,391 lb.	W3G/W3H	Crew	14,000 lb.
6108D54F40	Flip Top (H)	41.25"	1,452 lb.	F4G/F4H	Regular	15,000/16,500 lb.
6108D54H46	Standard	46"	1,411 lb.	X4G/X4H	Super	15,000/16,500 lb.
6108D54H60	Standard	60"	1,647 lb.	W4G/W4H	Crew	15,000/16,500 lb.
				F5G/X5H	Regular	17,500/19,500 lb.
				X5G/X5H	Super	17,500/19,500 lb.
				W5G/W5H	Crew	17,500/19,500 lb.
				F600	Regular	22,000 lb.

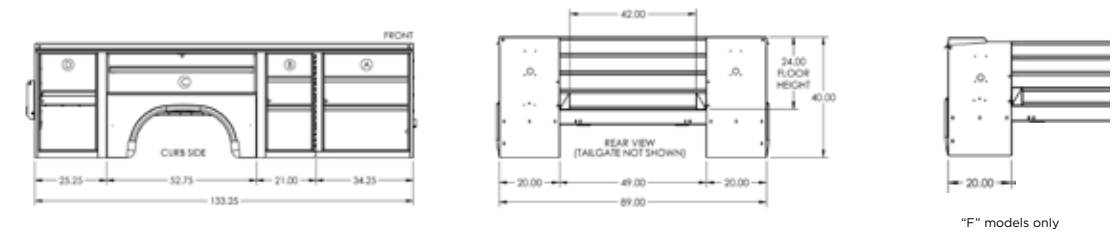
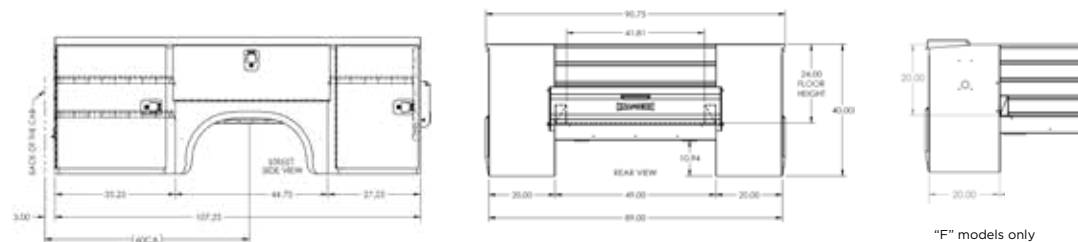

COMMITMENT TO CORROSION RESISTANCE

Corrosion won't be a concern when you buy quality Knapheide products. To give you the best corrosion protection, we utilize a state-of-the-art, custom-designed, 12-step, SST cathodic electrodeposition finishing system, called "E-Coat."

It bonds prime paint to steel by an electroplating process to give you a superior coat of primer, resulting in better corrosion protection compared to spraying methods.

This system allows us to create products with the highest level of corrosion resistance available.



FOLLOW US
LIKE US
TAG US



SIX YEAR, LIMITED TIME WARRANTY



**NO RUST
THROUGH**



**DOOR HINGES
WILL NOT FAIL OR
COME OFF BODY**



**LATCHES AND LOCK
CYLINDERS WILL NOT
FAIL TO OPERATE**



**SHELVES WILL NOT
BEND UNDER MAX.
LOAD OF 250 LBS.**

TO LEARN MORE VISIT
www.knapheide.com/warranty



NEVER SETTLE

If you are going to be a leader, it takes more than building a high-quality product. It means never being totally satisfied with that product, no matter how high quality it may be. It requires constant vigilance and a willingness to take a chance on something new. And it means exceeding expectations every time. As the industry changes, one thing never will—our commitment to making customers like you as productive and efficient as possible. We know you don't settle, and we don't either. That's why we want you never to settle for anything less than Knapheide on the back of your truck.

KNAPHEIDE. NEVER SETTLE.



The Knapheide Manufacturing Company
1848 Westphalia Strasse | Quincy, IL 62305
217-222-7131
www.knapheide.com